

Programul național pentru captarea și stocarea CO₂, cu orizont de timp 2020

SIMPOZION NAȚIONAL DE INFORMARE

Tehnologii de captare și transport

O = C = 0

Ing. FILIP George-Radu



Cuprins



- In loc de introducere



- Tehnologii de captare a CO₂



- Tehnologii de transport al CO₂





In loc de introducere



- Majoritatea tehnologiilor de captare a CO₂ au atins scara de proiect demonstrativ.



- Transportul CO₂ nu implică probleme tehnice deosebite.



- Stocarea CO₂ este posibilă tehnic.





- Tehnologii ajunse la scara de proiect demonstrativ:



- » Pre-combustie;
- » Oxicombustie;
- » Post-combustie.



- Tehnologii în fază de pilot care promit:



- » Arderea în buclă chimică;
- » Membrane moleculare;





Asimilată direct cu Ciclul Combinat cu Gazeificarea Cărbunelui și captura integrată a CO₂ (IGCC – Integrated Gaseification Combined Cycle).



Particularități:



- implică gazeificarea (transformarea în gaz de sinteză /gaz sintetic) a unui cărbune de calitate mai bună (lignit superior, huiă, antracit);

- nu se poate aplica la o instalație existentă;

- instalația este complicată și cu costuri investiționale ridicate.

- eficiență termică foarte bună, datorită capturii integrate a CO₂ și a utilizării ciclului termodinamic combinat care și în instalațiile uzuale fără gazeificare conduce la eficiențe mai mari decât ale unei centrale electrice uzuale utilizând un singur ciclu termodinamic;



Captarea CO₂ Pre-Combustie

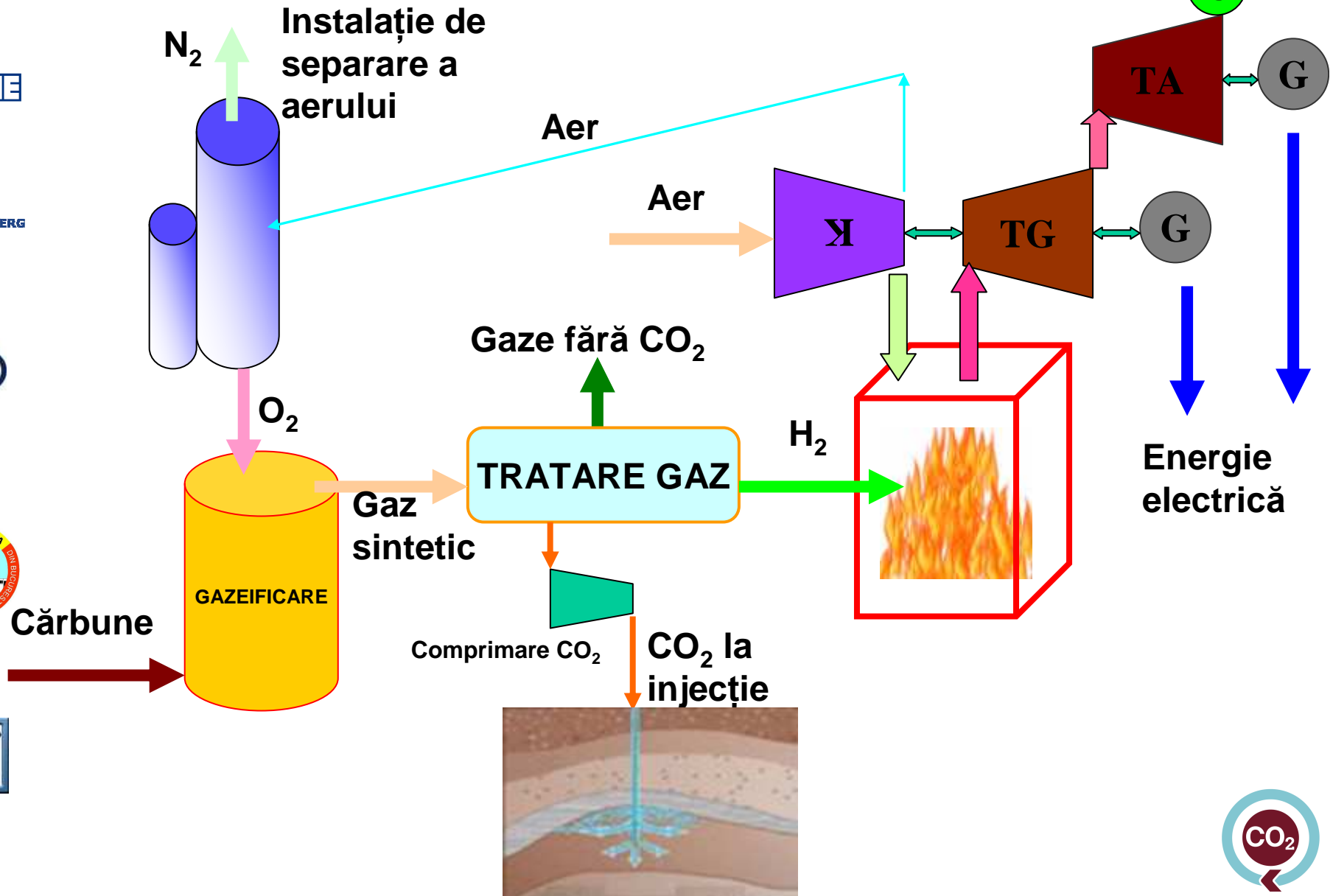

Captarea CO₂ Pre-Combustie

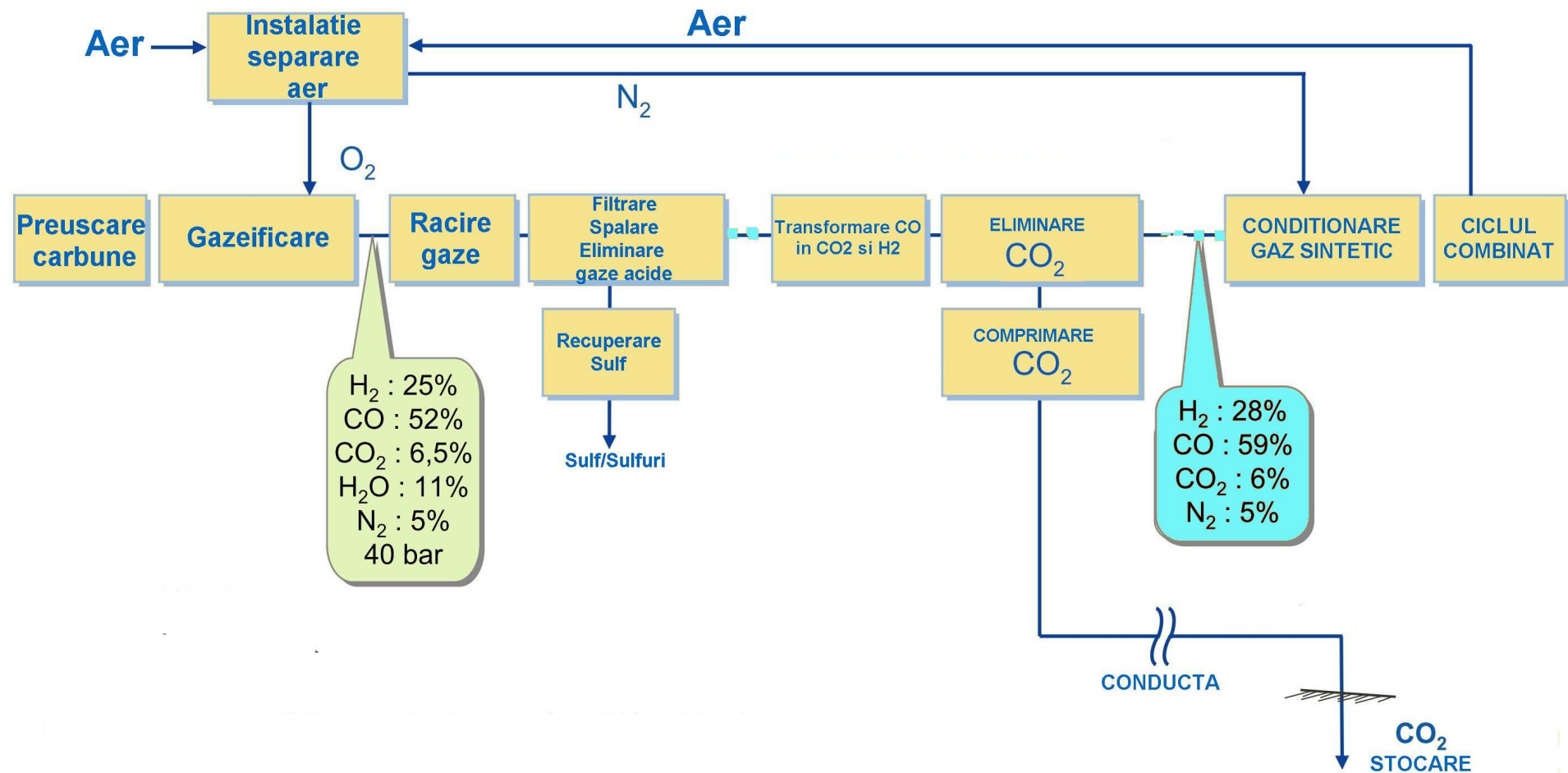

Captarea CO₂ Pre-Combustie

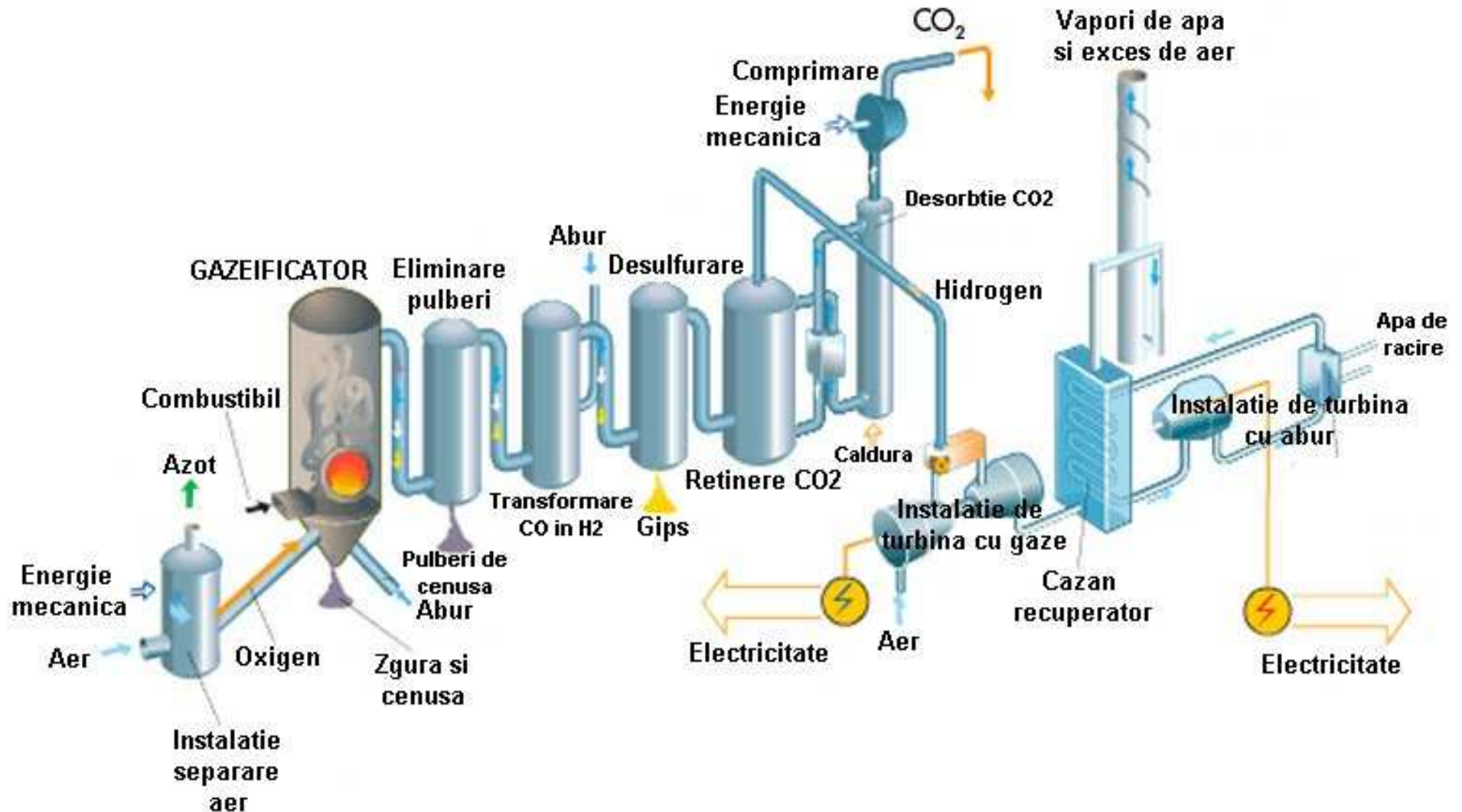

ARDEREA COMBUSTIBILULUI CU $O_2 \Rightarrow$ GAZE DE ARDERE CONCENTRATE ÎN CO_2 .

Particularități:



- se aplică mai greu centralelor existente;
- se pretează la orice fel și calitate de combustibil;
- Eficiența de reținere foarte bună;
- Consum propriu tehnologic mai redus față de tehnologia post-combustie, datorită necesarului mare de O_2 produs în instalația de separare a aerului;



Oxicombustie

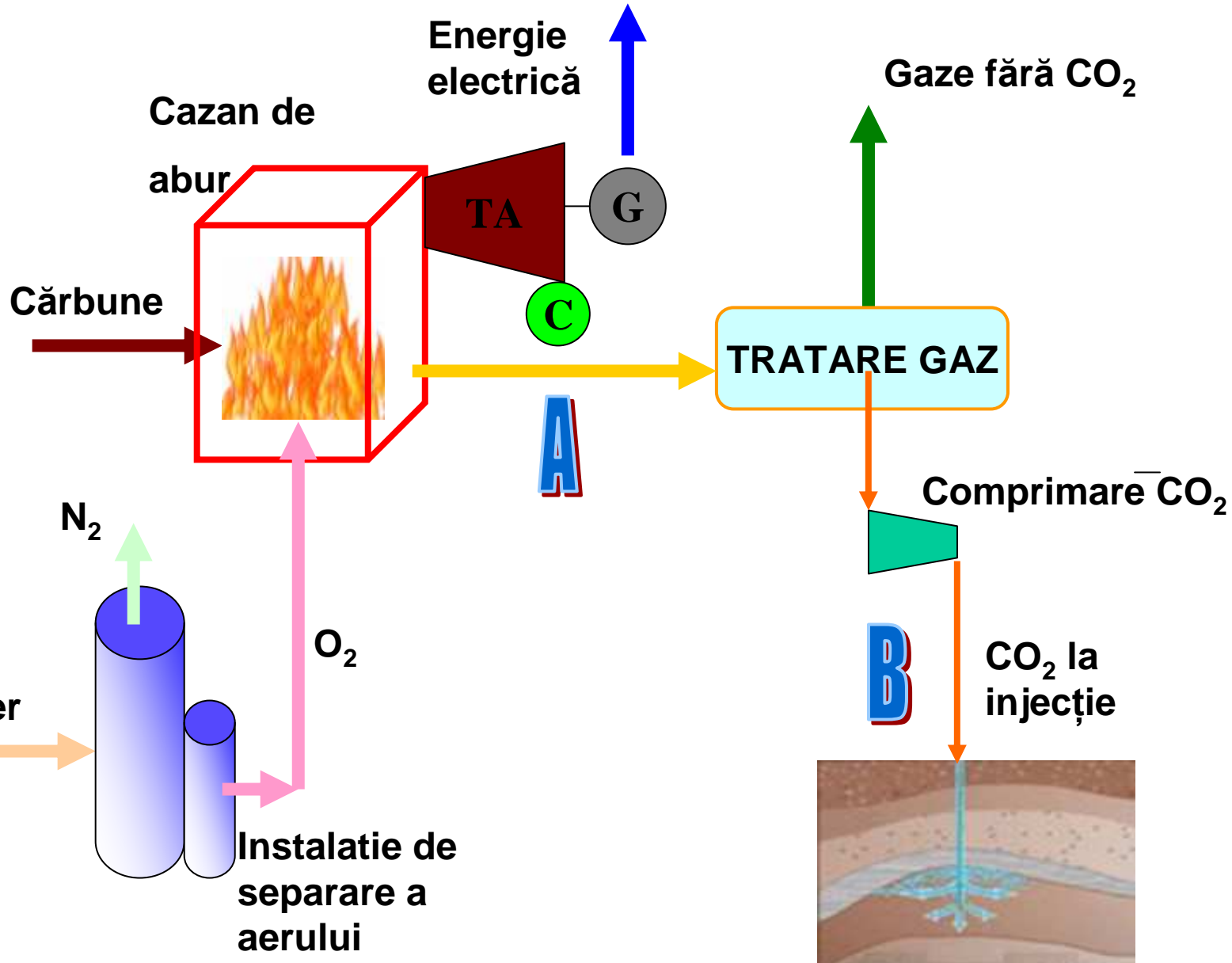

Oxicombustie

A

B

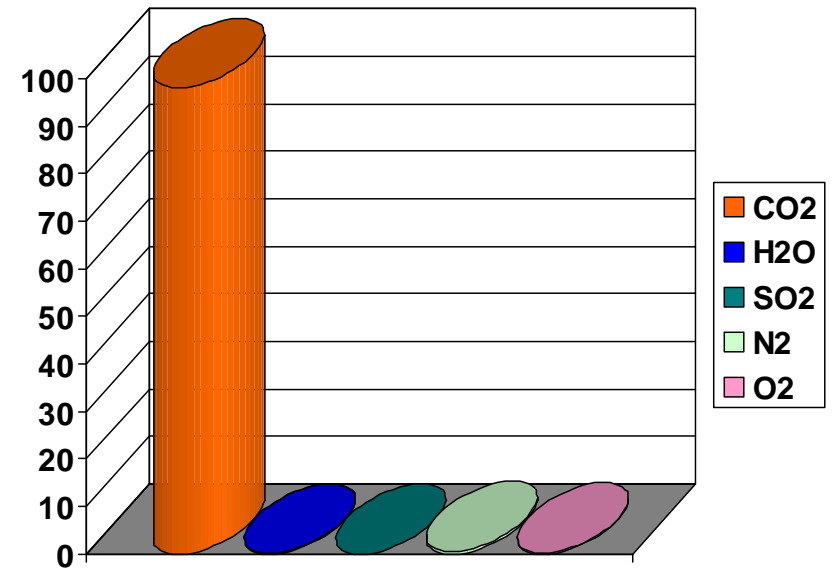
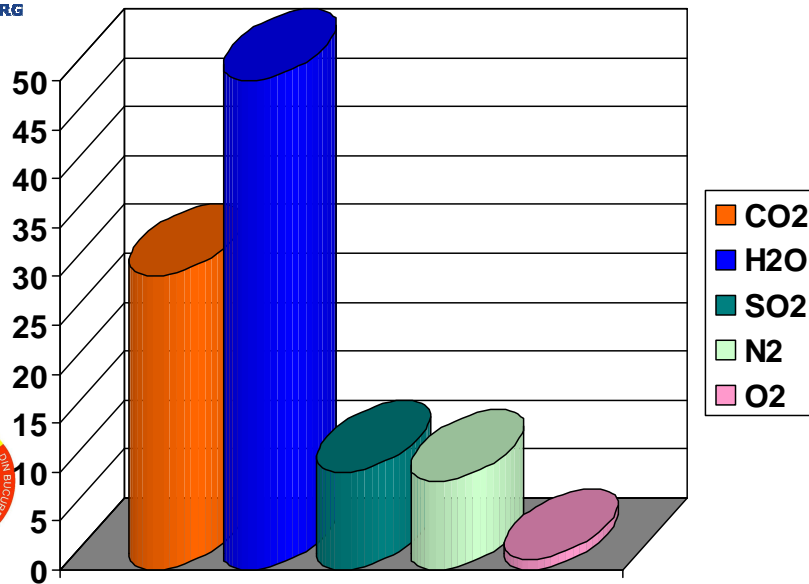

Oxicombustie

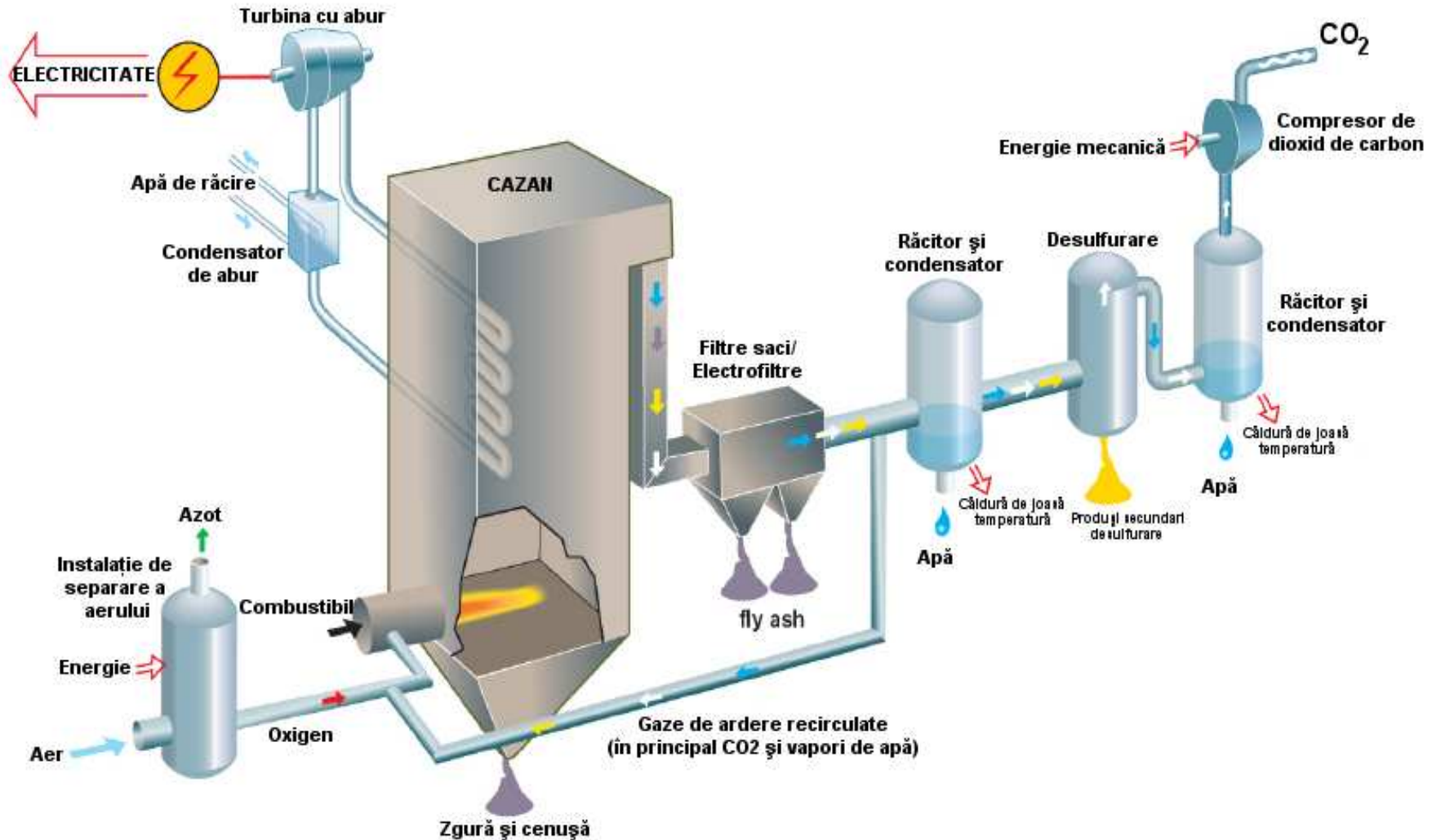

» IETE “SPĂLARE” CHIMICĂ A GAZELOR DE ARDERE LA IEȘIREA DIN INSTALAȚIA DE ARDERE



Particularități:

- Se aplică cu ușurință după orice tip de instalație de ardere, nouă sau veche și indiferent de tipul combustibilului;
- Eficiență de reținere peste 85%;
- Consum energetic ridicat;
- Instalație complexă, cu costuri ridicate;
- Solventul chimic de reținere a CO₂ care este în general toxic;
- Tehnologie mai bine stăpânită și dezvoltată;
- Integrare mai facilă;
- Proces tehnologic relativ simplu;



Captarea CO₂ Post-Combustie

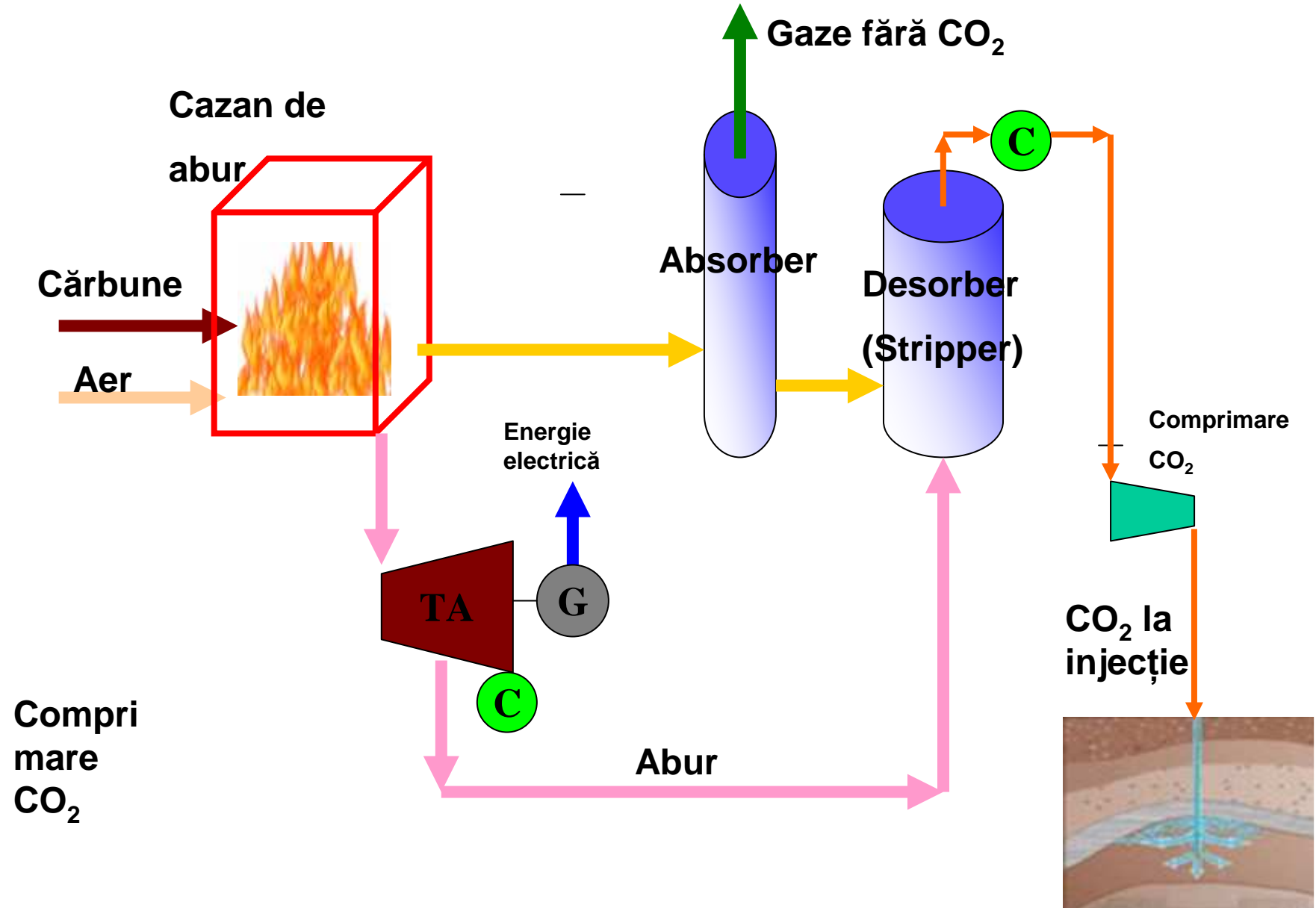

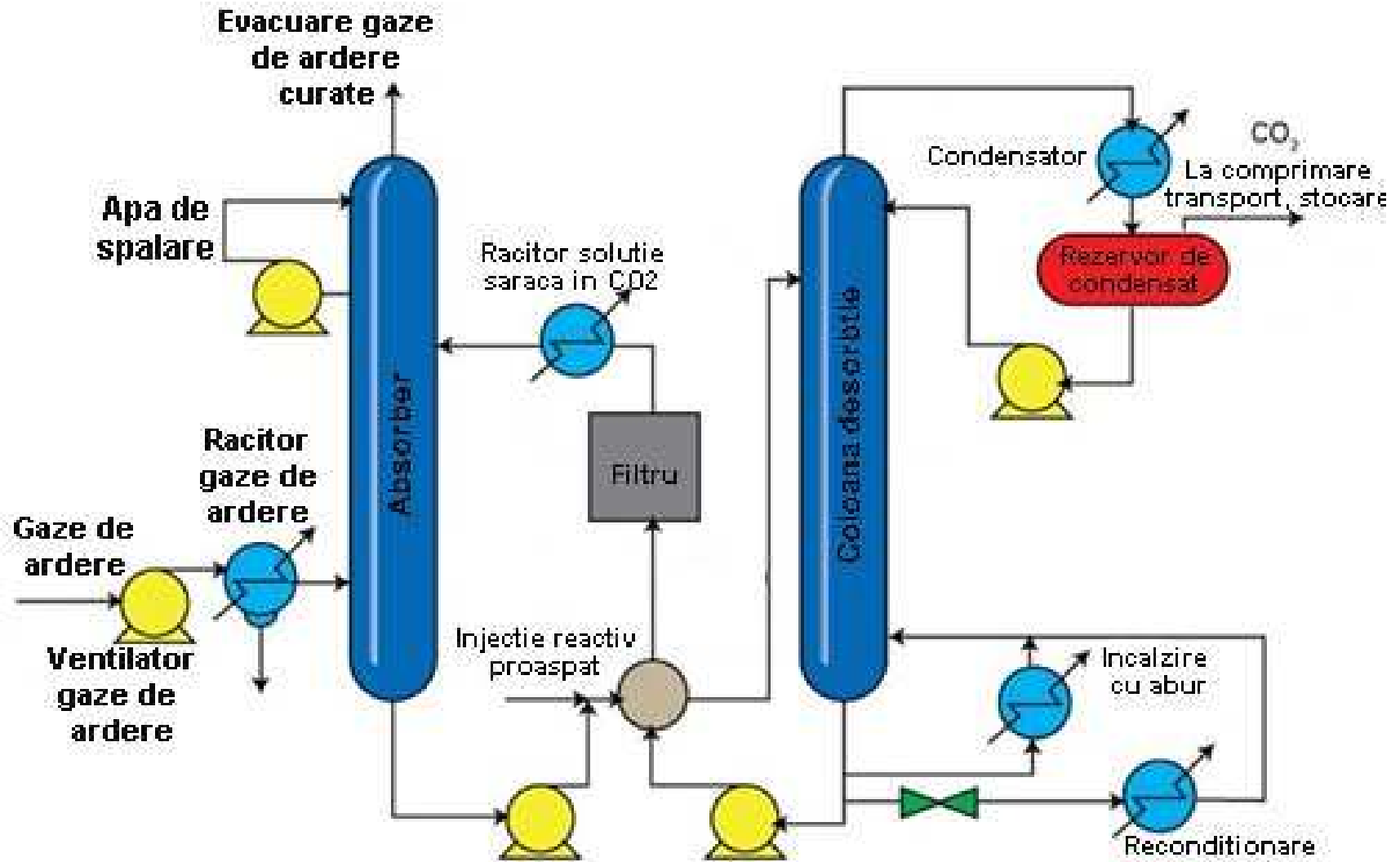

Captarea CO₂ Post-Combustie

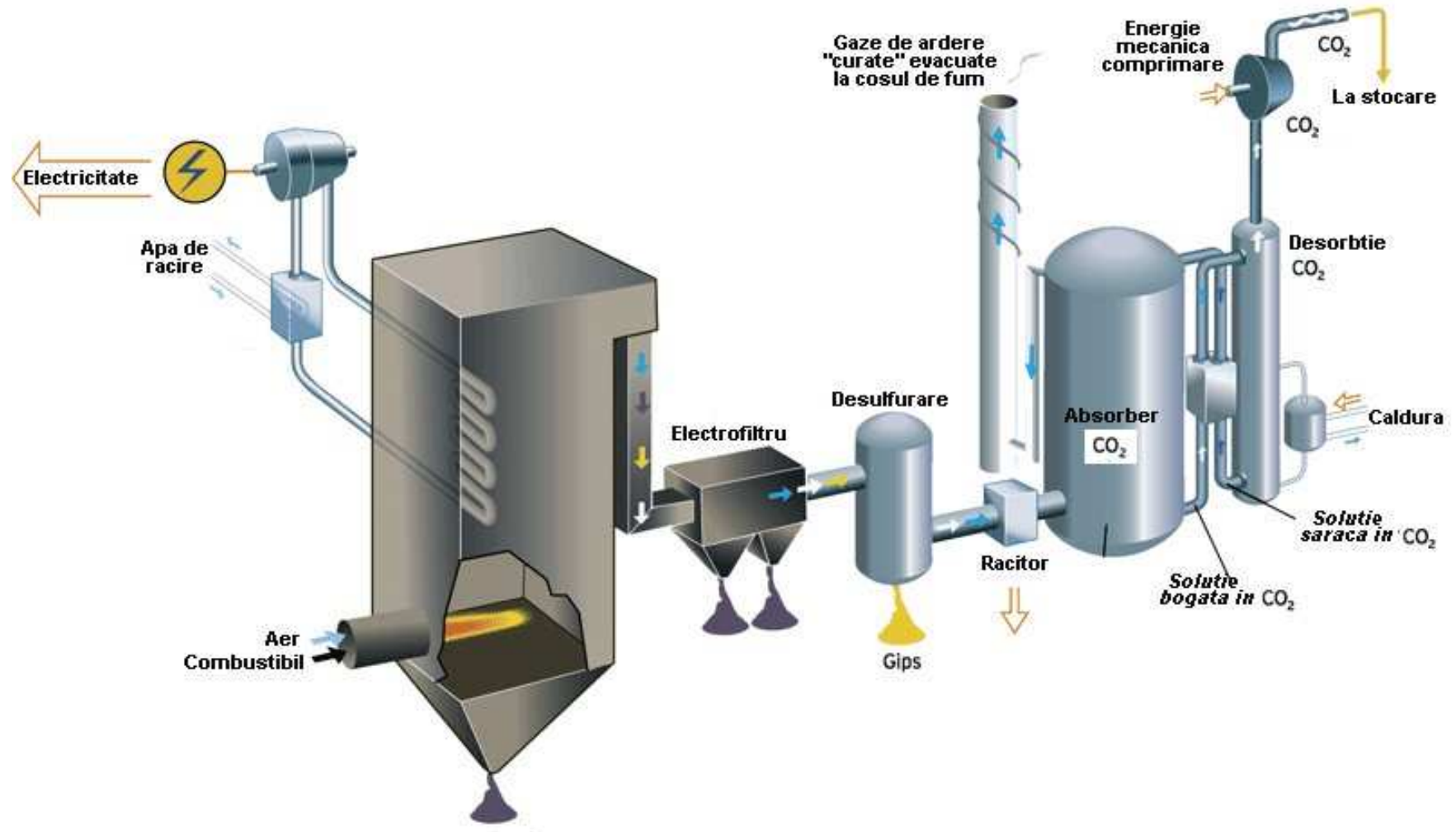

Captarea CO₂ Post-Combustie, cu Amoniac Răcit (Chilled Ammonia)

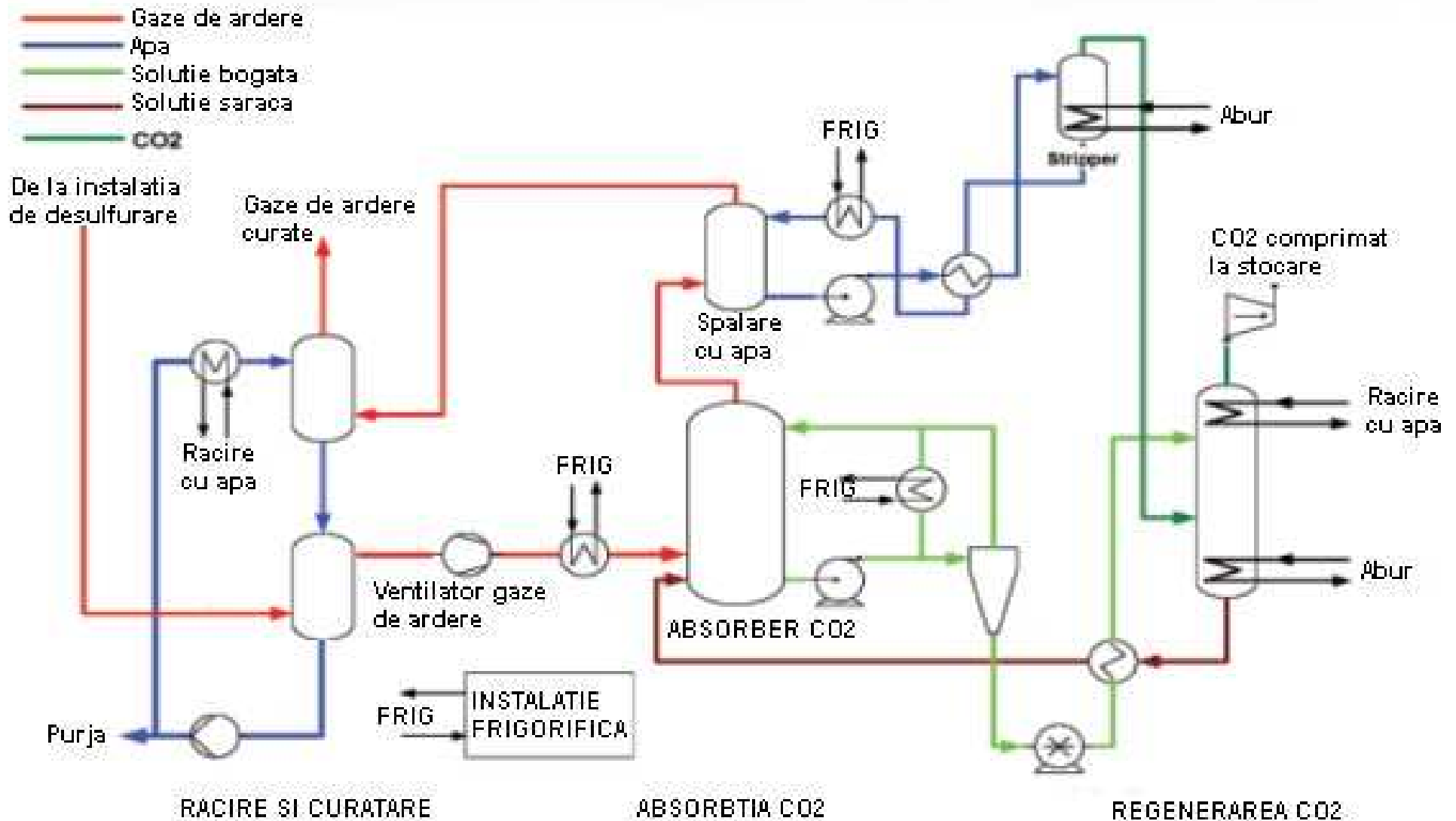

Tehnologii de captare a CO₂ în fază pilot

- **Arderea in buclă chimică:** transferul de oxigen se face utilizând un “purtător solid”, de regulă un metal;

- **Membrane moleculare:** Gazele de ardere sunt introduse sub presiune într-o incintă separată de o membrană moleculară permisivă doar pentru molecula de CO₂, astfel CO₂ trece prin membrană și gazele fără CO₂ își continuă drumul.

Arderea în buclă chimică

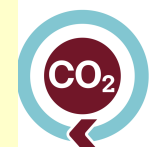
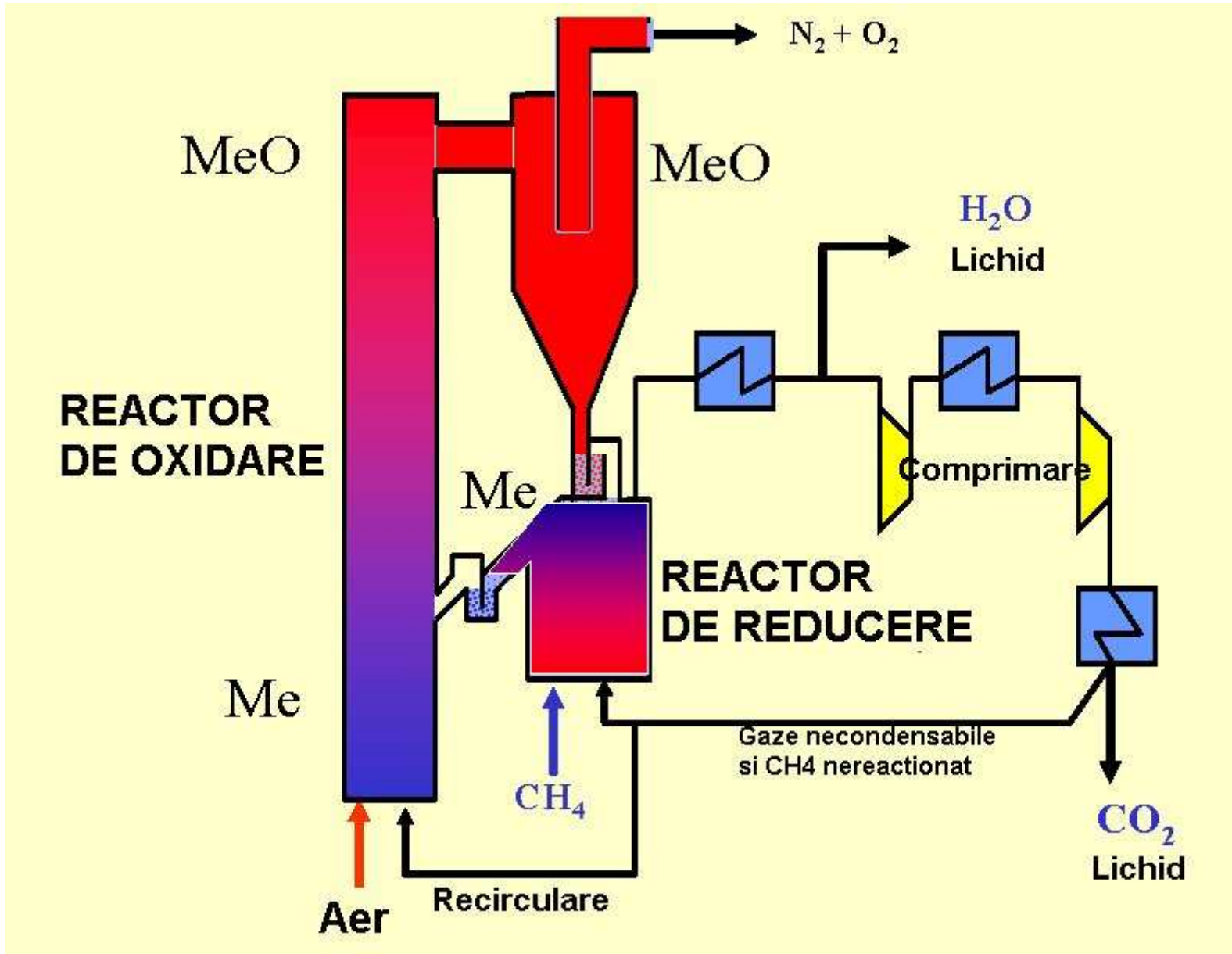

Membrane moleculare

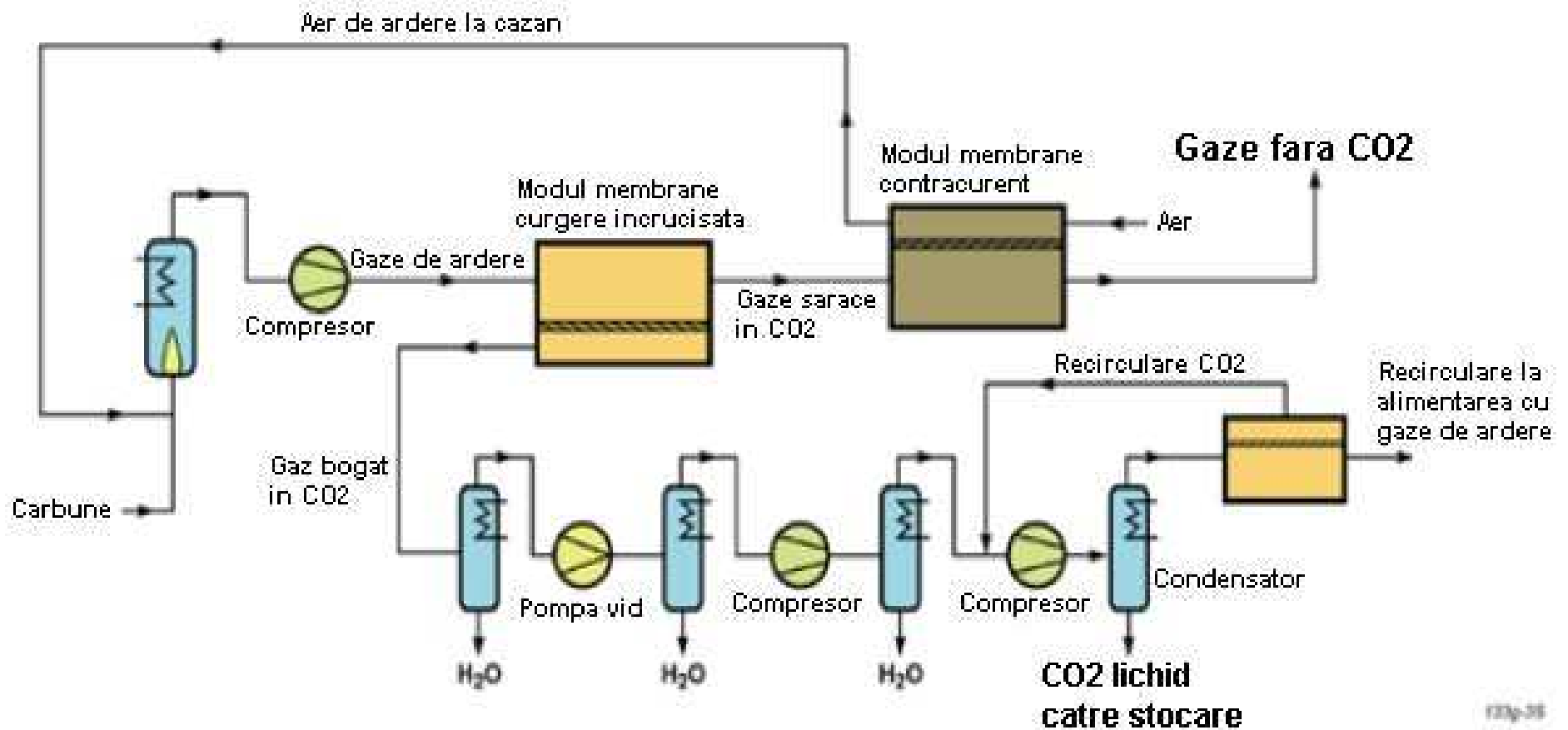

17/1/2016



Transportul CO₂



Transportul CO₂

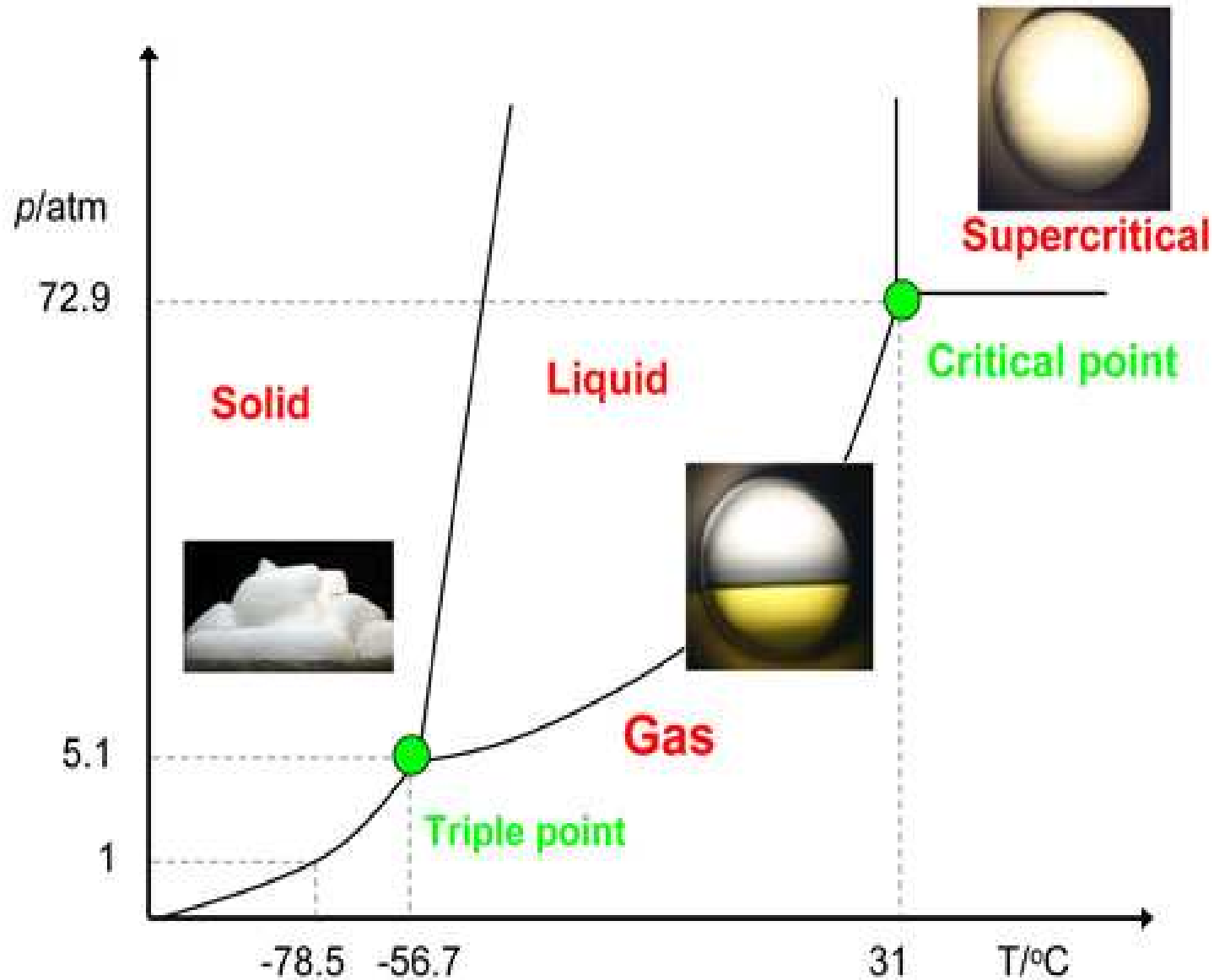

Transportul CO₂



- **Prin conducte:** fluid supracritic, $p > 73,8$ bari;



- **Cu camionul:** lichid, $p \approx 16$ bari, $t \approx -50$ °C;



- **Cu vaporul:** lichid, $p \approx 6,5$ bari, $t \approx 52$ °C





Vă mulțumesc!

FILIP GEORGE RADU

Colectiv **SCHIMBĂRI CLIMATICE**

Secția Ingineria Mediului

Divizia Energie & Mediu

telefon: 004021 206 12 62

fax: 004021 210 13 40

mobil: 004074 701 36 45,

radu.filip@ispe.ro

